



Galaxy 300i

3:3-phase: 10/15/20/30/40 kVA, 3:1-phase 10/15/20/30 kVA

Ruggedized and reliable three-phase power protection designed to prevent downtime and data loss for applications in industry and infrastructure.

schneider-electric.com/products

Life Is 

Schneider
Electric

Features and benefits

Galaxy 300i

Availability

Dual main inputs: Allow standard installation of one or two independent power sources

Automatic internal bypass: Built-in 100% rated bypass static switch prevents interruption by allowing load transfer to utility power during heavy overloads

Parallel 1+1 for redundancy: Connected equipment can be powered with two UPS units in parallel to increase system redundancy

Ruggedized design: With conformance-coated boards and IP21 kit with included dust filter to better withstand harsh environments

Integrated transformer: Can be configured on-site as either bypass or output transformer for full galvanic isolation and increased load protection

A powerful charger: Provides all-in-one solution for the most common runtime requirements

Designed for industry: Provides 100% nonlinear/unbalanced loads and genset compatibility

Serviceability

Manual maintenance bypass: Easily accessible maintenance bypass allows complete isolation of each part of the system, facilitating maintenance operations without power interruption

Front-access servicing: Push-open door and slide-out boards simplify installation and maintenance while minimizing space requirements

World-class service organization: With worldwide support and multiple levels of after-sales services, our package or individual on-site service options are structured for you to choose what APC™ by Schneider Electric can do for you

Economy

Power factor corrected input: Prevents the need for oversizing cables, circuit breakers, and generator

Temperature-compensated battery charging: Sensors monitor battery temperature and adjust charger voltage to prevent premature aging and extend battery lifetime

Reduced footprint: Compact wide or narrow tower makes best use of available space

Simplified installation

Easy to install: Wheeled unit rolls into place, and all wiring connections are easily identifiable for time-saving installation

Start-up wizard: Step-by-step guidance and intuitive menu screens for easy set-up and system navigation

Manageability

Flexible communication options: Remote and local monitoring and management capabilities with dry contact, modbus, and SNMP interface

User-friendly graphical interface: Easy-to-read LCD provides mimic diagrams, audible alarms, and multilanguage display, simplifying operation

Typical applications

- Industry processes (semiconductor, automotive, etc.)
- Transportation (metro, railways, etc.)
- Infrastructure
- Healthcare/Hospital
- Water facilities
- Mining facilities



Galaxy 300i

Economy

Optimized features: The Galaxy 300i unit is designed to provide optimal performance. The most in-demand features have been carefully selected to propose the right solution for predictable and reliable power protection, offering the benefits of a built-in transformer in a compact enclosure.

Reduced footprint: Narrow and wide tower options optimize the system footprint based on kVA power requirements.

Simplified maintenance: A full maintenance bypass with front access permits complete isolation of each part of the system and facilitates maintenance operations without power interruption.

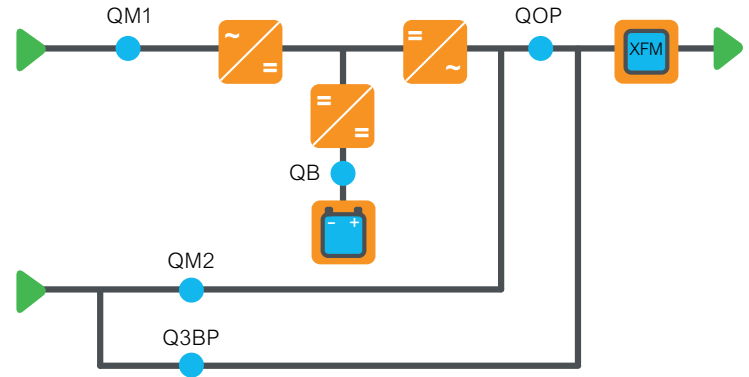

In the data center environment, our Galaxy 300i is fully managed through StruxureWare™ for Data Centers software, an integrated suite of data center infrastructure management applications. It enables businesses to prosper by managing their data centers across multiple domains, providing actionable intelligence for an ideal balance of high availability and peak efficiency throughout the entire data center life cycle. StruxureWare software applications and suites are a key element of Schneider Electric EcoStruxure™ integrated hardware and software system architecture — a system designed for intelligent energy management.



Options

External battery cabinet: For additional runtime. Supplied with breakers and temperature sensors.

Parallel kit: For 1+1 parallel redundancy. (G3HTPARKITS)

Empty cabinet for third-party batteries or transformers: Line up and match cabinet for third-party batteries and transformers.

Communication cards

- Network management card supplied with the product for Web/SNMP or modbus functions
- Optional card (AP9635) for additional features, such as modbus/Jbus over RS485, teleservice, and environmental sensors: temperature (AP9335T), temperature and humidity (AP9335TH), dry contact I/O (AP9810)

Schneider Electric Critical Power & Cooling Services (CPCS)

Provides the expertise, services, and support you need for your building, industry, power, or data center infrastructure. Our world-class life cycle services offer a smart way to install and maintain your critical applications, ensuring your systems are always running at peak performance.

Technical specifications

Rated power (kVA/kW)	10/8	15/12	20/16	30/24	40/32
Normal AC supply input					
Input voltage (V)	380/400/415 V (three-phase + neutral)				
Frequency (Hz)	45 – 65 Hz				
Input power factor	Up to 0.99 at >50% load				
THDI	<7% at full load				
Input voltage tolerance utility operation	340 V to 477 V at full load (-15% to +20% at 400 V)				
Dual mains input	Yes				
Output					
Nominal output voltage (V)	3:1 - 220/230/240 V				N/A
	3:3 - 380/400/415 V (three-phase + neutral)				
Efficiency at full load (on-line)	Up to 90.5%				
Output frequency	Mains synchronized in normal operation 50 Hz or 60 Hz + 0.1% free-running				
Overload capacity utility operation	125% for 2 minutes, 150% for 10 seconds				
Output voltage tolerance	+2% static, +5% at 100% load step				
Communication and management					
Communication interface	Network management card (AP9630/AP9635)				
Control panel	Multi-function LCD, status, and display console				
Dimensions and weight					
UPS dimensions (H x W x D) – 3:1	1,300 x 400 x 950 mm		1,300 x 500 x 950 mm		N/A
UPS dimensions (H x W x D) – 3:3	1,300 x 400 x 950 mm				1,300 x 500 x 950 mm
UPS Weight (kg) without transformer (3:1/3:3)	150/135 kg		190/135 kg		203 kg
UPS maximum weight (kg) with integrated transformer	445 kg				
Battery cabinet dimensions (H x W x D)	1,300 x 660 x 850 mm				
Battery cabinet — minimum weight	105 kg				
Battery cabinet — maximum weight	610 kg				
Regulatory					
Safety	IEC/EN62040-1-1				
EMC/EMI/RFI	IEC 62040-2				
Approvals	CE, TUV				
Environmental					
Operating temperature	0 °C to 40 °C (load conditions apply)				
Relative humidity	0 to 90% noncondensing				
Operating elevation	0 to 1,000 m at 100% load				
Max. audible noise at 1 m from unit	54 dBA at 100% load			53 dBA at 100% load	
Protection class	IP21				